

Introduction - Police Telecommunications, Rajasthan Police.

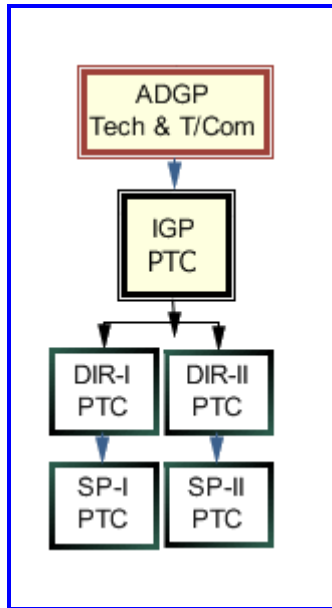

Allocation of Work:

ADDL.DGP TELE-COMMUNICATIONS AND TECHNICAL

1. All matters related with Police Telecommunications.
2. Dealing with NCRB, DCPW and CFSL through BPR&D.
3. Publication of Police Magazines.
4. Technical up gradation of Police including evaluation of needs/ requirements and identification of equipment,
5. Preparation and implementation of computerization schemes (except SCRB)
6. FSL.

IGP (TELE-COMMUNICATIONS)

IGP Police Tele-communications will assist Addl. DGP (Tele-Communications and Technical) in all matters related with Police Tele-communications.

The allocation of the work of Directorate of Police Telecommunications among the I.G.P. (PTC) and Director PTC and the two other Directors will be as under:-

1. IGP PTC

IGP PTC will perform all the statutory powers of Director PTC as mentioned in GF&AR, CCA & RSR Rules. He will exercise over all control, administration, supervision and ensure efficient functioning of PTC.

2. DIRECTOR (I) PTC

He will look after the following work of PTC.

- 1) Establishment Branch
- 2) Accounts section
- 3) Main Stores
- 4) D.E. Cell
- 5) PTC Lines
- 6) Any other work assigned by IGP, PTC.

S.P. (I) will report to Director (I).

2. DIRECTOR (II) PTC:-

He will look after the following work of PTC.

- 1) Training Branch including Training School.
- 2) Communication Centre, Transmission Room, SCR, PHQ PBX and Cipher Section.
- 3) Headquarter Workshop
- 4) Communication/Monitoring Branch
- 5) Web Designing and Development cell, PIS and all other IT related applications in Rajasthan Police.
- 6) Any other work assigned by IGP, PTC

S.P. (II) will report to Director (II).